

butterfly valve

type **QUADAX** - buttweld type

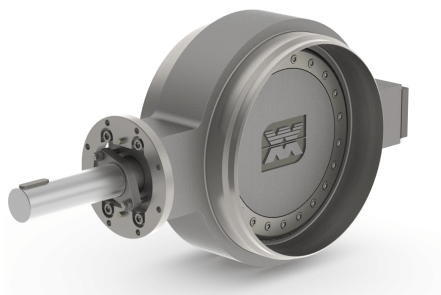

butterfly valve bare shaft
pressure range PN 0-160 bar
orifice DN 80-1000 mm
connection buttweld ends

⚠ Above stated body materials refer to the valve port connections that get in contact with the media only!

body materials carbon steel, stainless steel, special material (duplex, inconell)
valve seat materials inconell, others on request
seal materials graphite / stainless steel, inconell, stainless steel, PTFE

details needed

- size
- pipe connection
- operating pressure
- flow rate
- Δp
- closing time
- media
- process temperature
- outside temperature

general specifications

ports	buttsweld ends	
function	NC / NO / DA	depending upon actuator
pressure range	body pressure	0 to 160 bar
	Δp standard shaft	52 bar in both directions
	Δp optional shaft	100 bar in both directions
Kv value	m³/h	
leakage rate	1 DIN 3230	
	A DIN EN 12266	
	BS 6364	
	Fire safe	
flow direction	A ⇌ B as marked	
switching time	s DN/100	
process- and outside temperature	standard	-10 °C to +450 °C
	with special materials	-270 °C to +800 °C
limit switches	option	
approvals	PED / Fire safe / BAM / TA Luft / ATEX in further	
weight	kg see table	
additional equipment	upon request	

⚠ The valves' technical design is based on media and application requirements. This can lead to deviations from the general specifications shown on the data sheet with regards to the design, sealing materials and characteristics.

⚠ If order or application specifications are incomplete or imprecise there exists a risk of an incorrect technical design of the valve for the required application. As a consequence, the physical and / or chemical properties of the materials or seals used, may not be suitable for the intended application.

Kv-curve

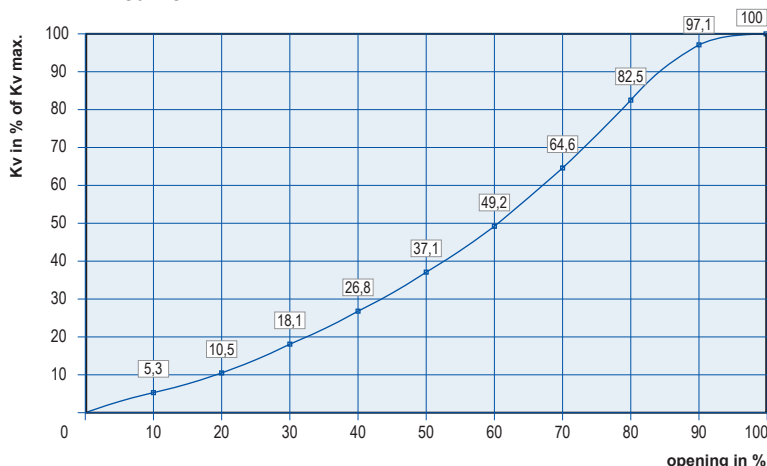

■ specifications not highlighted are standard
 ■ specifications highlighted in grey are optional

type QUADAX - butt weld type

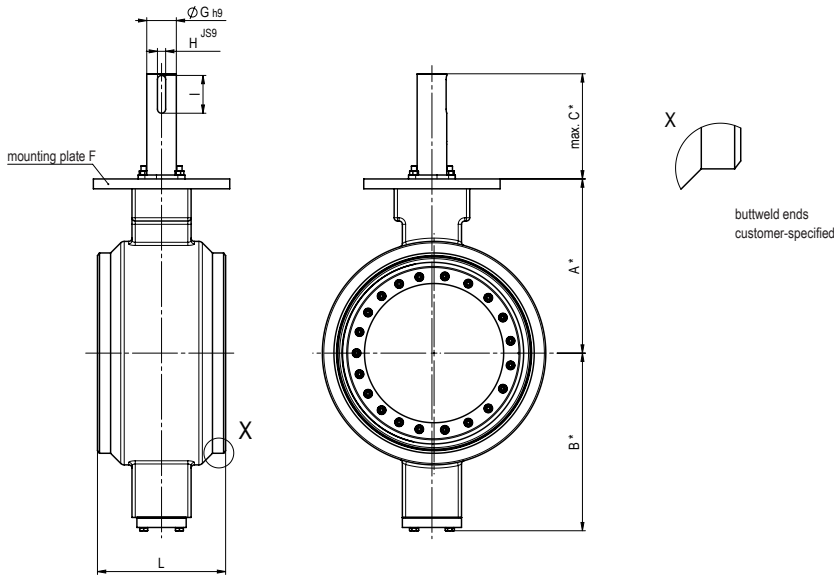

* dimensions for trim X only

size	(mm) (inch)	80 3	100 4	125 5	150 6	200 8	250 10	300 12	350 14	400 16	450 18	500 20	600 24	700 28	750 30	800 32	900 36	1000 40	
pipe cl to mounting plate		A	128	162	190	203	240	279	305	325	385	405	440	530	630	630	700	830	920
pipe cl to cover screws		B	129	158	186	204	241	281	307	333	383	403	441	541	643	643	713	836	926
bare shaft length for direct mounting		C	95	125	135	145	180	180	180	280	289	300	320	320	367	367	367	398	398
bare shaft length for adapter		C	51	68	68	68	85	85	85	173	170	170	170	210	-	-	-	-	-
mounting plate F ISO 5211	(others on request)	F	F07	F10	F12	F14	F16	F16	F16	F25	F30	F30	F35	F35	F40	F40	F40	F48	F48
trim A	20 bar max. 290 psi max.	G	-	-	-	-	-	-	40	45	50	55	55	70	90	90	100	110	120
		H	-	-	-	-	-	-	12	14	14	16	16	20	25	25	28	32	32
		I	-	-	-	-	-	-	45	60	60	80	80	90	115	115	125	140	160
trim X (standard)	52 bar max. 754 psi max.	G	18	20	22	32	32	40	45	55	65	70	75	90	110	110	130	150	160
		H	6	6	6	10	10	12	14	16	18	20	20	25	32	32	32	36	40
		I	28	28	40	40	40	45	60	80	88	90	90	115	140	140	180	180	200
trim B	104 bar max. 1500 psi max.	G	-	-	-	-	45	55	65	75	90	95	110	130	150	150	180	190	220
		H	-	-	-	-	14	16	18	20	25	25	32	32	36	36	45	45	50
		I	-	-	-	-	60	80	88	90	115	125	140	180	180	220	250	280	
trim C	155 bar max. 2250 psi max.	G	20	28	32	40	50	65	75	90	110	110	130	150	170	170	200	230	250
		H	6	8	10	12	14	18	20	25	32	32	32	36	40	40	45	50	56
		I	28	40	40	45	60	88	90	115	140	140	180	180	200	200	240	280	320
DIN 3202 F4		L	180	190	200	210	230	250	270	290	310	330	350	390	430	470	470	510	550
kv-value (m³/h)	trim A Δp max. 20 bar		-	-	-	-	-	-	3837	5478	7944	10735	12921	20651	25473	32661	36123	47565	56131
	trim X Δp max. 52 bar		118	258	418	654	1445	2451	3720	5120	7321	9986	12118	19253	23081	30015	33343	43215	51398
	trim B Δp max. 104 bar		-	-	-	-	1254	2123	3180	4459	6282	8738	10245	16458	19826	22286	28632	38954	44444
	trim C Δp max. 155 bar		101	208	344	576	1164	1916	2926	3962	5659	7989	9442	15002	18231	21026	26779	34693	40870
cv-value (gal/min)	trim A Δp max. 290 psi		-	-	-	-	-	-	4462	6370	9237	12483	15024	24013	29620	37978	42003	55308	65269
	trim X Δp max. 754 psi		137	300	486	760	1680	2850	4314	5953	8513	11612	14091	22387	26838	31702	38771	50250	59765
	trim B Δp max. 1500 psi		-	-	-	-	1458	2469	3698	5185	7305	10160	11913	19137	23053	25914	33293	45295	51679
	trim C Δp max. 2250 psi		117	242	400	670	1353	2228	3402	4607	6580	9290	10979	17444	21199	24658	31138	40341	47523
weight (standard)	(ca. kg)		14	15	21	27	59	71	112	144	212	265	322	452	562	722	810	912	1010